

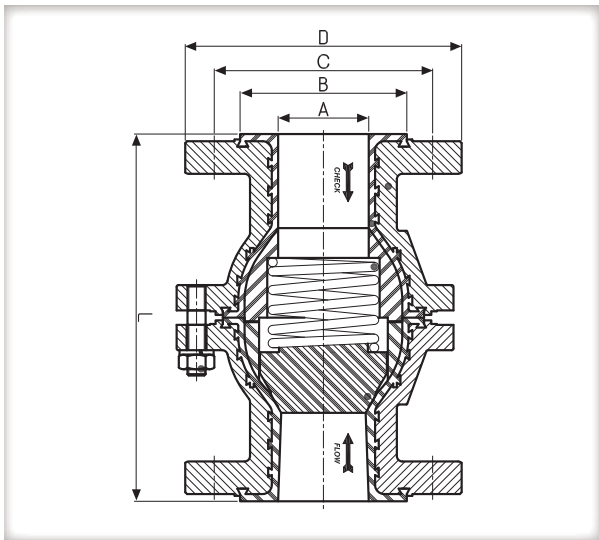

PFA LINED SPRING CHECK VALVE

High Performance and Creative Technology Company

www.fluonics.com



SPRING CHECK VALVE

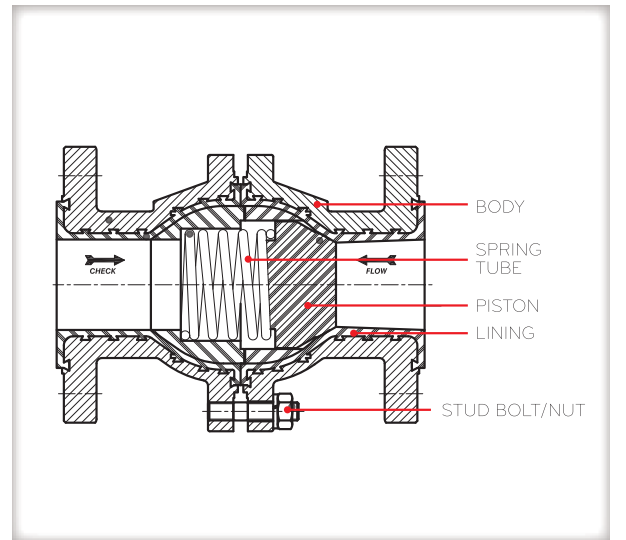

GENERAL TECHNICAL DATA

Size (mm) :	DN 20, 25, 40, 50, 80, 100
(inch) :	3/4", 1", 1-1/2", 2", 3", 4"
Pressure rating :	Max. 10 bar
Face to face dimension :	FLUONICS Standard
Temperature :	200°C(MAX.)
Flanges :	JIS 10K, ANSI 150lbs

Lining with high durability

The lining resin is locked by grooves allow the valves to be used on high vacuum, pressure and temperature application without lining collapse, shrinkage and blowout.

Lining virgin pure PFA

Suitable for corrosive, hazardous, pure hot and highly permeating media

Shut-off elements

Solid piston are made of PTFE

PFA LINED SPRING CHECK VALVE

High Performance and Creative Technology Company

DIMENSIONS

NOMINAL SIZE	3/4" / 20A		1" / 25A		1-1/2" / 40A		2" / 50A		3" / 80A		4" / 100A	
	ANSI	JIS	ANSI	JIS	ANSI	JIS	ANSI	JIS	ANSI	JIS	ANSI	JIS
A	25	25	25	25	36	36	50	50	76	76	95	95
B	51	51	51	51	73	73	92	92	125	125	149	149
C	70	75	79	90	98.5	105	120.5	120	152.4	150	190.5	175
D	99	100	108	125	127	140	152.5	155	190.5	185	228.6	210
L	152.4		152.4		178		203		241		292	
Ref.	B		C		D		E		G		H	

MATERIAL

PARTS	MATERIAL
BODY	ASTM A351-CF8 / A216-WCB
BODY LINED	PFA
SPRING	SUS304
SPRING TUBE	PFA TUBE
PISTON	PTFE
STUD BOLT/NUT	SUS304

ORDERING INFORMATION

Order example	J	B	C	S	EP
Connection	J				
Valve type		SPC			
Nominal size			E		
Valve body material				W	
Surface					EP

Valve body materials	Ref.
CARBON STEEL(A216-WCB/SCPH2)	W
STAINLESS STEEL(A351-CF8/SCS13A)	S

Connections	Ref.	Valve type	Ref.	Surface finish	Ref.
JIS 10K	J	Swing Check Valve	SWC	Electropolished	EP
ANSI 150 lbs	A	Spring Check Valve	SPC	Epoxy coated	P

Head Office & Factory

#561-11, Gwang Gyeok, Ho-jeo, Wonju-Si, Kangwon-Do, Korea
 Tel : 82-33-731-3550 / Fax : 82-33-731-3559 / www.fluonics.com