

PFA LINED PLUG VALVE

High Performance and Technology Creative company
www.fluonics.com



Head Office & Factory

#561-11, Gwang Gyeok, Ho-Jeo, Wonju-Si, Kangwon-Do, Korea
Tel : 82-33-731-3550 / Fax : 82-33-731-3559
www.fluonics.com





Contents

- 3 Lining Materials
- 4 Features
- 5 Materials
- 6 Plug valve
- 7 Automated Plug valve

Lining Materials

PFA

PFA exhibits thermal characteristics like to PTFE, being able to withstand super low to high temperatures (260°C Maximum temp. for continuous use). It is also transparent and mechanically strong under high temperature. It is easily workable besides applicable with extrusion molding to the same degree as general thermoset plastics. It is used where purity is important, such as semiconductor wafer baskets, piping couplings and non-corrosive linings. PFA has better mechanical strength at high temperatures than FEP, and excellent moldability for easy processing by extrusion, compression, blow, transfer and injection molding methods. Due to the high bonding strength of the carbon, fluorine and oxygen atoms, PFA demonstrates nearly the same outstanding capabilities as PTFE in temperatures ranging from -200°C to +260°C.

FEP

FEP is a copolymer of tetrafluoroethylene and hexafluoropropylene. FEP consists of carbon atoms and fluorine atoms, as does PTFE, and has a molecular structure in which one of the fluorine atoms bonded to the carbon atoms. FEP has a lower melt viscosity than PTFE and can be processed like other molten thermoplastic resins by extrusion, transfer, injection, and compression molding. Because the bonding energy between its carbon and fluorine atoms is so high, and because the carbon chain is completely surrounded by fluorine atoms, FEP fluorocarbon polymer retains excellent thermal, electrical, and chemical stability. Therefore, it shows high performance in electrical, chemical, and medical applications in temperatures ranging from extremely low to extremely high (-200°C ~ +200°C / -328°F ~ +392°F).

PTFE

The fluorine atoms completely cover the carbon chain backbone and protect the carbon-carbon bond from attack. The fluorine atoms are also responsible for the low surface energy and exceptional frictional characteristics of PTFE. Because of very high melt viscosity, PTFE does not flow above its melting point. It requires special polymer processing like paste extrusion, compression molding and sintering. Among all the fluoroplastics products, PTFE offers the highest heat resistances at 260°C (maximum temp. for continuous use). It is not corroded by most chemicals and has good electrical insulation and dielectric characteristics. Moreover, it has a unique non-stick property and the lowest coefficient of friction amongst solids. It is the most widely used fluoroplastics, now found in O-rings, gaskets, bearings, tube, wiring, hot plates and irons because of its non-stick property, as well as chemical tank linings.

Property	PFA			FEP			PTFE		
	Testing Method	Value	Unit	Testing Method	Value	Unit	Testing Method	Value	Unit
Specific Gravity	ASTM D-3307	2.14-2.16	—	ASTM D-2116	2.12-2.17	—	ASTM D-3307	2.14-2.20	—
Melt Flow Rate	ASTM D-3307	7-8	g/10 min	ASTM D-2116	6	g/10 min	—	—	—
Melting Point	ASTM D-3307	304	°C	ASTM D-2116	260	°C	ASTM D-3307	327	°C
Tensile Strength	ASTM D-3307	33.3 (4835)	MPa (psi)	ASTM D-2116	31	MPa (psi)	ASTM D-3307	13.7-34.3 (1990-4980)	MPa (psi)
Elongation	ASTM D-3307	420	%	ASTM D-2116	370	%	ASTM D-3307	200-400	%
Chemical resistance	—	Excellent		ASTM D-2116	Excellent		—	Excellent	—

Features

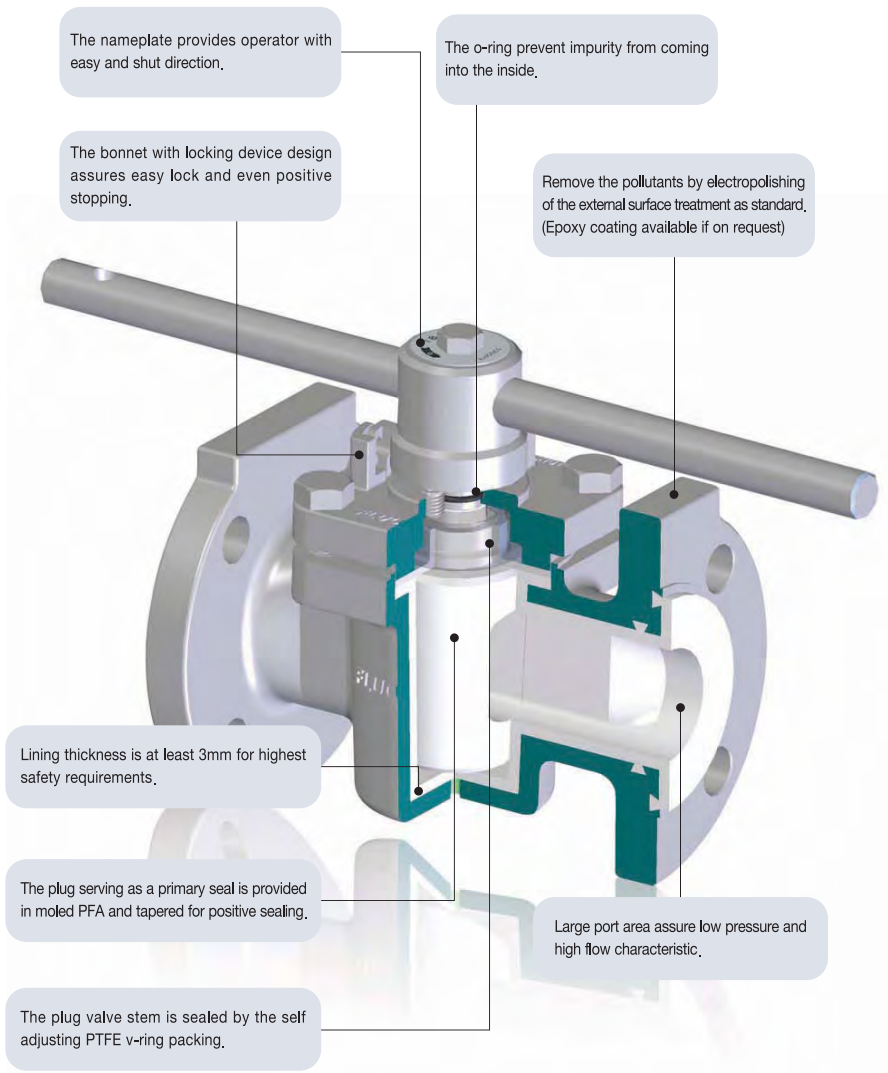

Materials

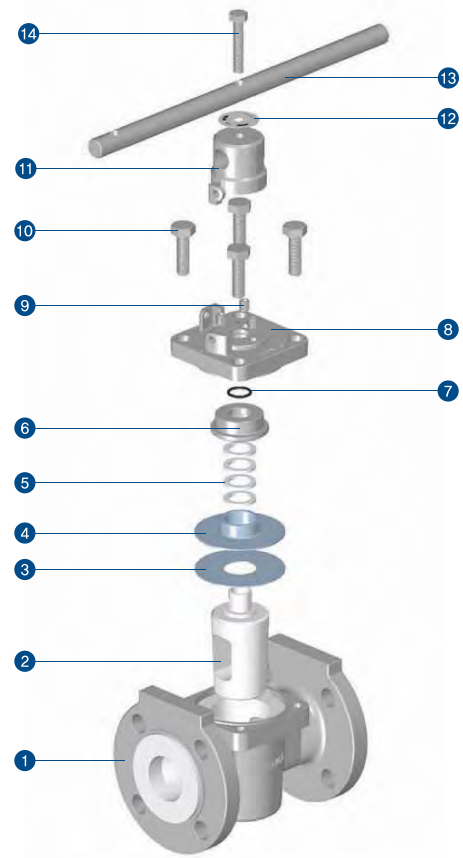

Item No.	DESCRIPTION	MATERIAL		
		STAINLESS STEEL	CARBON STEEL	DUCTILE IRON
1	BODY	ASTM A351 CF8/CF8M, PFA lined	ASTM A216 WCB, PFA lined	ASTM A395 Ductile iron, PFA lined
2	PLUG	ASTM A351 CF8/CF8M, PFA lined	ASTM A351 CF8/CF8M, ASTM A216 WCB, PFA lined	ASTM A351 CF8/CF8M, ASTM A216 WCB, PFA lined
3	DIAPHRAGM	PTFE / PFA	PTFE / PFA	PTFE / PFA
4	DIAPHRAGM SEAT	PTFE	PTFE	PTFE
5	STEM SEAL	PTFE	PTFE	PTFE
6	COMPRESSOR	ASTM A351 CF8/CF8M	ASTM A351 CF8/CF8M	ASTM A351 CF8/CF8M
7	O-RING	NBR	NBR	NBR
8	BONNET	ASTM A351 CF8/CF8M	ASTM A351 CF8/CF8M, ASTM A216 WCB	ASTM A351 CF8/CF8M, ASTM A216 WCB
9	ADJUSTING BOLT	ASTM A193 B8	ASTM A193 B8	ASTM A193 B8
10	BONNET BOLT	ASTM A193 B8	ASTM A193 B8	ASTM A193 B8
11	HUB	ASTM A351 CF8/CF8M	ASTM A351 CF8/CF8M	ASTM A351 CF8/CF8M
12	NAME PLATE	SUS304	SUS304	SUS304
13	HANDLE	ASTM A351 CF8, STEEL, ZINC PLATED	ASTM A351 CF8, STEEL, ZINC PLATED	ASTM A351 CF8, STEEL, ZINC PLATED
14	HUB BOLT	ASTM A193 B8	ASTM A193 B8	ASTM A193 B8

Plug valve

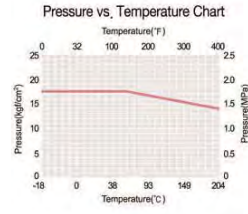
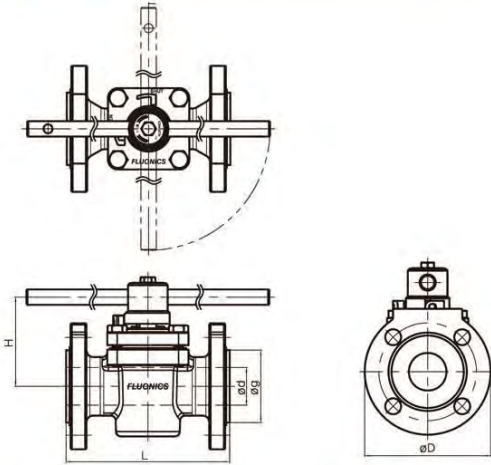

SIZE	Operating Torques(N,m)	Operating Torques(kgf,cm)
1/2(15A)	18	180
3/4(20A)	18	180
1(25A)	20	200
1 1/2(40A)	29.5	300
2(50A)	64	650
3(80A)	118	1200
4(100A)	147	1500

Available Size : 1/2"-8"(15A~200A) Flange rating : ANSI 150lbs JIS 10K

Nominal size	ø d	ø D		L	ø g	H	Ref.
		ANSI150	JIS10K				
1/2 (15A)	13	89	95	108	35	65	A
3/4 (20A)	18	99	100	117	43	65	B
1 (25A)	25	108	125	127	51	75	C
1 1/2 (40A)	38	127	140	165	73	90	D
2 (50A)	50	152	155	178	92	100	E
3 (80A)	76	190	185	203	125	121	G
4 (100A)	100	229	210	229	150	152	H
6 (150A)	150	279	280	267	212	253	J
8 (200A)	200	343	330	292	261	340	K

Ordering information

Connections	Ref.	Valve type	Ref.	Operating	Ref.
JIS 10K	J	Diaphragm valve	D	Manual Lever	L
ANSI 150lbs	A	Ball valve	B	Manual Wormgear	W
		Plug valve	P	Actuator	A

Valve body materials	Ref.	Surface finish	Ref.
PFA lined Carbon Steel(A216-WCB)	W	Electropolished	EP
PFA lined Stainless Steel(A351-CF8)	S	Epoxy coated	P
PFA lined Stainless Steel(A351-CF8M)	M	Electropolished + Buffed	EB
PFA lined Ductile iron(A395 D.I.)	F		

Order example	J	P	M	C	S	EP
Connection	J					
Valve type		P				
Operating			M			
Nominal size				C		
Valve body material					S	
Surface finish						EP

Automated Plug valve

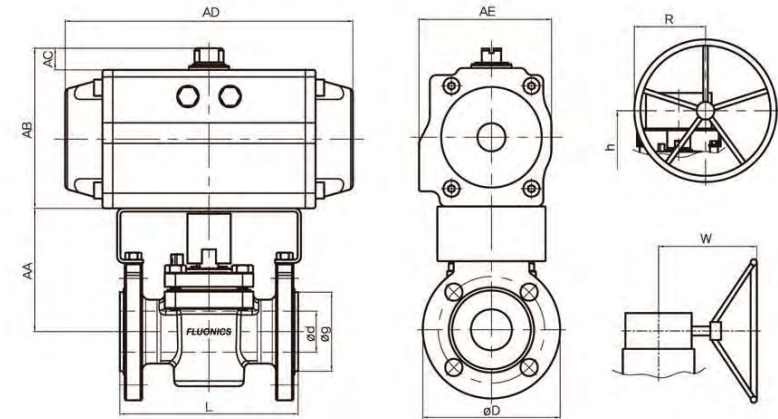

Spring Return

Nominal size	AA	AB	AC	AD	AE	ø D		L	ø g
						ANSI150	JIS10K		
1/2 (15A)	89.5	136	20	247	108	89	95	108	35
3/4 (20A)	89.5	136	20	247	108	99	100	117	43
1 (25A)	99	179	20	347	151	108	125	127	51
1 1/2 (40A)	114	179	20	347	151	127	140	165	73
2 (50A)	127.5	226	30	467	190	152	155	178	92
3 (80A)	145	251	30	497	206	190	185	203	125
4 (100A)	168	277	30	555	227	229	210	229	150

Double Acting

Nominal size	AA	AB	AC	AD	AE	ø D		L	ø g
						ANSI150	JIS10K		
1/2 (15A)	89.5	124	20	210	96	89	95	108	35
3/4 (20A)	89.5	124	20	210	96	99	100	117	43
1 (25A)	99	136	20	247	108	108	125	127	51
1 1/2 (40A)	114	136	20	247	108	127	140	165	73
2 (50A)	127.5	179	20	347	151	152	155	178	92
3 (80A)	145	209	30	414	172	190	185	203	125
4 (100A)	168	251	30	497	206	229	210	229	150

Worm Gear

Nominal size	R	W	h	ø D		L	ø g
				ANSI150	JIS10K		
4 (100A)	175	286	211	229	210	229	150
6 (150A)	175	286	290	279	280	267	212
8 (200A)	200	300	340	343	330	292	261